

AIIMS - 2012

Time : 3½ Hours

Max. Marks : 200

PHYSICS

- Which of the following current must be zero in an unbiased *PN* junction diode?
 - Current due to majority charge carriers (both electrons and holes).
 - Current due to minority charge carriers (both electrons and holes).
 - Current due to majority and minority charge carriers.
 - Current due to majority and minority charge carriers (only holes).
- In an AC circuit, voltage $V = V_0 \sin \omega t$ and inductor L is connected across the circuit. Then the instantaneous power will be
 - $\frac{V_0^2}{2\omega L} \sin \omega t$
 - $\frac{-V_0^2}{2\omega L} \sin \omega t$
 - $\frac{-V_0^2}{2\omega L} \sin 2\omega t$
 - $\frac{V_0^2}{\omega L} \sin 2\omega t$
- Two sinusoidal waves of intensity I having same frequency and same amplitude interferes constructively at a point. The resultant intensity at a point will be
 - I
 - $2I$
 - $4I$
 - $8I$
- In a convex lens of focal length F , the minimum distance between an object and its real image must be
 - $3F$
 - $4F$
 - $\frac{3}{2}F$
 - $2F$
- In Young's double slit experiment, fringe order is represented by m , then fringe width is
 - Independent of m .
 - Directly proportional to m .
 - Directly proportional to $(2m + 1)$.
 - Inversely proportional to $(2m + 1)$.
- Half life of a radio-active element is 8 years, how much amount will be present after 32 years?
 - $\frac{1}{4}$
 - $\frac{1}{8}$
 - $\frac{1}{16}$
 - $\frac{1}{32}$

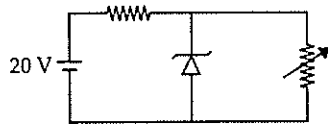
- In the given circuit, the voltage across the load is maintained at 12 V. The current in the zener diode varies from 0-50 mA. What is the maximum wattage of the diode?
 
 - 12 W
 - 6 W
 - 0.6 W
 - 1.2 W

- A photon is incident having frequency $1 \times 10^{14} \text{ sec}^{-1}$. Threshold frequency of metal is $5 \times 10^{13} \text{ sec}^{-1}$. Find the kinetic energy of the ejected electron.
 - $3.3 \times 10^{-21} \text{ J}$
 - $6.6 \times 10^{-21} \text{ J}$
 - $3.3 \times 10^{-20} \text{ J}$
 - $6.6 \times 10^{-20} \text{ J}$
- In a given series LCR circuit $R = 4 \Omega$, $X_L = 5 \Omega$ and $X_C = 8 \Omega$, the current
 - Leads the voltage by $\tan^{-1}(3/4)$.
 - Leads the voltage by $\tan^{-1}(5/8)$.
 - Lags the voltage by $\tan^{-1}(3/4)$.
 - Lags the voltage by $\tan^{-1}(5/8)$.
- A wire of mass 100 g, length 1 m and current 5 A is balanced in mid air by a magnetic field B , then find the value of B .
 - 0.2 T
 - 0.1 T
 - 0.5 T
 - 0.6 T
- Dimensional formula of ΔQ , heat supplied to the system is given by
 - $[M^1 L^2 T^{-2}]$
 - $[M^1 L^1 T^{-2}]$
 - $[M^1 L^2 T^{-1}]$
 - $[ML^1 T^{-1}]$
- A toroid with mean radius r_0 , diameter $2a$ have N turns carrying current I . What is the magnetic field B inside the toroid?
 - $\frac{NI}{2\pi r_0}$
 - $\frac{NI}{2\pi(r_0 + a)}$
 - $\frac{NI}{\pi(r_0 + a)}$
 - zero
- Identify incorrect for electric charge q
 - quantised
 - conserved
 - additive
 - non-transferable.

* Based on memory. Courtesy : Allen Career Institute, Kota (Rajasthan)

14. Which of the following parameter in the series LCR circuit is analogous to driving force $F(t)$ in mechanics?
- (a) $\frac{V_0}{L}$ (b) inductance L
 (c) capacitance C (d) voltage V_0
15. The minimum magnetic dipole moment of electron in hydrogen atom is
- (a) $\frac{eh}{2\pi m}$ (b) $\frac{eh}{4\pi m}$
 (c) $\frac{eh}{\pi m}$ (d) 0
16. A 4 kg roller is attached to a massless spring of spring constant $k = 100$ N/m. It rolls without slipping along a frictionless horizontal road. The roller is displaced from its equilibrium position by 10 cm and then released. Its maximum speed will be
- (a) 0.5 m s^{-1} (b) 0.6 m s^{-1}
 (c) 0.4 m s^{-1} (d) 0.8 m s^{-1}
17. Total energy of the electron in hydrogen atom above 0 eV leads to
- (a) continuation of energy states.
 (b) large number of discrete ionised states.
 (c) balmer series. (d) paschen series.
18. Two wires carrying
- (a) Parallel current repel each other.
 (b) Antiparallel current attract each other.
 (c) Antiparallel current repel each other.
 (d) Equal magnitudes of antiparallel current attract each other.
19. A particle is thrown vertically upwards with velocity 11.2 km s^{-1} from the surface of earth. Calculate its velocity at height $3R$. Where R is the radius of earth.
- (a) $\approx 9.25 \text{ km s}^{-1}$ (b) $\approx 5.6 \text{ km s}^{-1}$
 (c) $\approx 11.2 \text{ km s}^{-1}$ (d) $\approx 4.3 \text{ km s}^{-1}$
20. Gamma decay takes place
- (a) Prior to alpha decay.
 (b) Prior to beta decay.
 (c) Prior to positron decay.
 (d) Due to de-excitment of nuclear levels.
21. Calculate the kinetic energy of the electron having wavelength 1 nm.
- (a) 2.1 eV (b) 3.1 eV
 (c) 1.5 eV (d) 4.2 eV
22. A spherical body of diameter D is falling in viscous medium. Its terminal velocity is proportional to
- (a) $V_t \propto D^{1/2}$ (b) $V_t \propto D^{3/2}$
 (c) $V_t \propto D^2$ (d) $V_t \propto D^{5/2}$
23. Electric field outside a long wire carrying charge q is proportional to
- (a) $\frac{1}{r}$ (b) $\frac{1}{r^2}$
 (c) $\frac{1}{r^{3/5}}$ (d) $\frac{1}{r^{3/2}}$
24. If 2 kg mass is rotating on a circular path of radius 0.8 m with angular velocity of 44 rad/sec. If radius of the path becomes 1 m, then what will be the value of angular velocity?
- (a) 28.16 rad/sec (b) 19.28 rad/sec
 (c) 8.12 rad/sec (d) 35.26 rad/sec
25. A light ray is incident on a glass slab, it is partially reflected and partially transmitted. Then the reflected ray is
- (a) completely polarised and highly intense.
 (b) partially polarised and poorly intense.
 (c) partially polarised and highly intense.
 (d) completely polarised and poorly intense.
26. An electron projected with velocity $\vec{v} = v_0 \hat{i}$ in the electric field $\vec{E} = E_0 \hat{j}$. Trace the path followed by the electron E_0 .
- (a) Parabola (b) Circle
 (c) Straight line in $+y$ direction.
 (d) Straight line in $-y$ direction.
27. Find out the correct relation for the dependance of change in acceleration due to gravity on the angle at the latitude, due to rotation of earth
- (a) $dg \propto \cos\phi$ (b) $dg \propto \cos^2\phi$
 (c) $dg \propto \cos^{3/2}\phi$ (d) $dg \propto \frac{1}{\cos\phi}$
28. Two conductors having same width and length, thickness d_1 and d_2 , thermal conductivity K_1 and K_2 are placed one above the another. Find the equivalent thermal conductivity.
- (a) $\frac{(d_1 + d_2)(K_1 d_2 + K_2 d_1)}{2(K_1 + K_2)}$
 (b) $\frac{(d_1 - d_2)(K_1 d_2 + K_2 d_1)}{2(K_1 + K_2)}$
 (c) $\frac{K_1 d_1 + K_2 d_2}{d_1 + d_2}$ (d) $\frac{K_1 + K_2}{d_1 + d_2}$

29. Calculate I for the given circuit diagram.

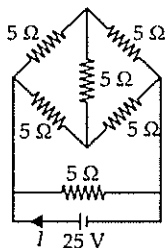

- (a) 10 A (b) 5 A (c) 2.5 A (d) 20 A
30. A solid cylinder, a circular disc, a solid sphere and a hollow cylinder of the same radius are placed on an inclined plane. Which of the following will have maximum acceleration at the bottom of the plane?
 (a) Circular disc. (b) Solid cylinder.
 (c) Solid sphere. (d) Hollow cylinder.
31. Calculate the heat emitted by a bulb of 100 W in 1 min.
 (a) 100 J (b) 1000 J
 (c) 600 J (d) 6000 J
32. Degree of freedom for polyatomic gas
 (a) ≥ 4 (b) ≥ 5 (c) ≥ 6 (d) ≥ 7
33. A particle moving about its equilibrium position with equation $y = -ax - bt$. Interpret the condition
 (a) It will always perform the SHM.
 (b) It can never perform the SHM.
 (c) It can perform SHM only when $t \geq \frac{bx}{a}$.
 (d) It can perform SHM only when $t \leq \frac{bx}{a}$.
34. Conversion of water to steam is accompanied by which process?
 (a) Adiabatic. (b) Isothermal.
 (c) Isochoric. (d) Cyclic.
35. An ideal gas is taken through the cycle $A \rightarrow B \rightarrow C \rightarrow A$, as shown in figure. If the net heat supplied to the gas in the cycle is 5 J the work done by the gas in the process $A \rightarrow B$ is
 (a) 2 J (b) 3 J (c) 4 J (d) 5 J
36. What is the slope for an isothermal process?
 (a) $\frac{P}{V}$ (b) $-\frac{P}{V}$ (c) Zero (d) ∞
37. The frequency order for X-rays (A), γ -rays (B), UV rays (C) is
 (a) $B > A > C$ (b) $A > B > C$
 (c) $C > B > A$ (d) $A > C > B$
38. For a common-emitter transistor, input current is $5 \mu\text{A}$, $\beta = 100$ circuit is operated at load resistance of 10 k Ω , then voltage across collector emitter will be
 (a) 5 V (b) 10 V (c) 12.5 V (d) 7.5 V
39. Find the voltage drop across a capacitor connected with a resistance and a battery of 60 V in series after a long time.
 (a) 0 V (b) 60 V (c) 30 V (d) 38 V
40. The nucleus ${}^m_n X$ emits one α particle and 2β -particles. The resulting nucleus is
 (a) ${}^{m-4}_{n-2} Y$ (b) ${}^{m-6}_{n-4} Z$
 (c) ${}^{m-6}_{n} Z$ (d) ${}^{m-4}_{n} X$

Directions: In the following questions (41-60), a statement of assertion (A) is followed by a statement of reason (R). Mark the correct choice as:

- (a) If both assertion and reason are true and reason is the correct explanation of assertion.
 (b) If both assertion and reason are true but reason is not the correct explanation of assertion.
 (c) If assertion is true but reason is false.
 (d) If both assertion and reason are false.
41. Assertion: Maximum air flow due to convection does not occur at the north pole but it occurs at 30°N .
 Reason: There is maximum temperature difference between equator and 30°N
42. Assertion: A thick lens shows more chromatic aberration.
 Reason: Thick lens behave as many thin lenses.
43. Assertion: Surface energy of an oil drop is same whether placed on glass or water surface.
 Reason: Surface energy is dependent only on the properties of oil.

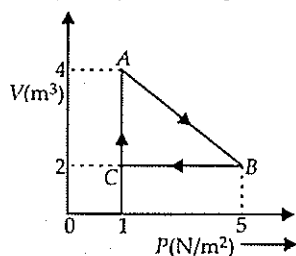

44. **Assertion** : Magnetic force is always perpendicular to the magnetic field.
Reason : Electric force is along the direction of electric field.
45. **Assertion** : Animate object can accelerate in the absence of external force.
Reason : Newton's second law is not applicable on animate object.
46. **Assertion** : A planar circular loop of area A and carrying current I is equivalent to magnetic dipole of dipole moment $M = IA$.
Reason : At large distances, magnetic field of circular loop and magnetic dipole is same.
47. **Assertion** : In elastic collision, kinetic energy is conserved.
Reason : Energy is always conserved.
48. **Assertion** : Bohr's atomic model cannot be used to explain multiple electron species.
Reason : It does not take inter-electronic interactions in account.
49. **Assertion** : The focal length of objective lens in telescope is much more than that of eye piece.
Reason : Telescope has high resolving power due to large focal length.
50. **Assertion** : Total energy of electron in a hydrogen atom is negative.
Reason : It is bounded to the nucleus.
51. **Assertion** : Vibrational energy of diatomic molecule corresponding to each degree of freedom is $k_B T$.
Reason : For every molecule, vibrational degree of freedom is 2.
52. **Assertion** : A superconductor is a perfect diamagnetic substance.
Reason : A superconductor is a perfect conductor.
53. **Assertion** : An electrostatic field line never form closed loop.
Reason : Electrostatic field is a conservative field.
54. **Assertion** : A charged particle can be accelerated in a cyclotron by the alternate distribution of the field.
Reason : Energy of charged particle is increased by the field applied.
55. **Assertion** : At rest, radium is decayed into Radon and an α -particle. They both moves back to back of each other.
Reason : Splitting of radioactive particle is based on conservation of linear momentum.
56. **Assertion** : In electromagnetic waves electric field and magnetic field lines are perpendicular to each other.
Reason : Electric field and magnetic field are self sustaining.
57. **Assertion** : Gauss's law shows diversion when inverse square law is not obeyed.
Reason : Gauss's law is a consequence of conservation of charges.
58. **Assertion** : More energy is released in fusion than fission.
Reason : More number of nucleons take part in fission.
59. **Assertion** : γ -radiation emission occurs after α and β decay.
Reason : Energy levels occur in nucleus.
60. **Assertion** : Turbulence is always dissipative.
Reason : High reynold number promotes turbulence.

CHEMISTRY

61. Threshold frequency of a metal is $5 \times 10^{13} \text{ s}^{-1}$ upon which $1 \times 10^{14} \text{ s}^{-1}$ frequency light is focused. Then the maximum kinetic energy of emitted electron is
 (a) 3.3×10^{-21} (b) 3.3×10^{-20}
 (c) 6.6×10^{-21} (d) 6.6×10^{-20}
62. Which is the major product formed when $\text{C}_6\text{H}_5\text{CONHC}_6\text{H}_5$ undergoes nitration?

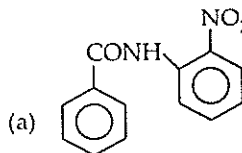

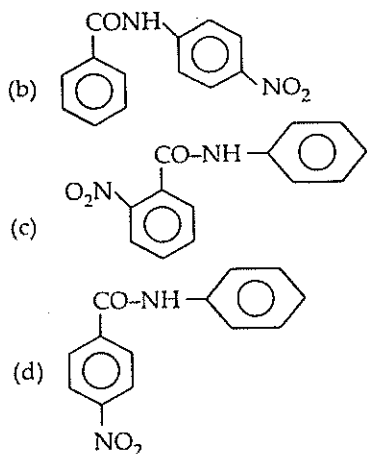

63. How many P = O bond present in $(\text{HPO}_3)_3$?
 (a) 0 (b) 3 (c) 6 (d) 9

64. At equilibrium which is correct?
 (a) $\Delta G = 0$ (b) $\Delta S = 0$
 (c) $\Delta H = 0$ (d) $\Delta G^\circ = 0$

65. If phthalic acid is treated with NH_3 and then it is first heated weakly then strongly, the final product formed is

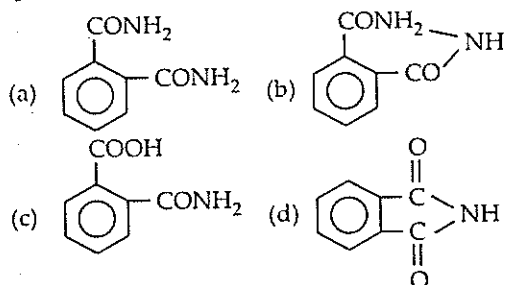

66. In bcc structure contribution of corner and central atom is

(a) $\frac{1}{8}, 1$ (b) $\frac{1}{4}, \frac{1}{8}$ (c) $\frac{1}{8}, \frac{1}{2}$ (d) $1, \frac{1}{2}$

67. Arrange the following gases in order of their critical temperature.

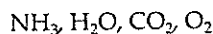

(a) $\text{NH}_3 > \text{H}_2\text{O} > \text{CO}_2 > \text{O}_2$
 (b) $\text{O}_2 > \text{CO}_2 > \text{H}_2\text{O} > \text{NH}_3$
 (c) $\text{H}_2\text{O} > \text{NH}_3 > \text{CO}_2 > \text{O}_2$
 (d) $\text{CO}_2 > \text{O}_2 > \text{H}_2\text{O} > \text{NH}_3$

68. Bond dissociation energy of CH_4 is 360 kJ/mol and C_2H_6 is 620 kJ/mol. Then bond dissociation energy of C — C bond is

(a) 170 kJ/mol (b) 50 kJ/mol
 (c) 80 kJ/mol (d) 220 kJ/mol

69. For silicon which is not correct?

(a) It is a type of silicate.
 (b) It is thermally unstable.
 (c) It is hydrophilic.
 (d) Repeating unit is R_2SiO .

70. In Bohr's orbit, $\frac{nh}{2\pi}$ indicates

(a) Momentum (b) Kinetic energy
 (c) Potential energy (d) Angular momentum

71. Which is not stable under ambient condition?

(a) $\text{TiO}_2, \text{Ti}^{+4}$ (b) VO, V^{+4}
 (c) $\text{VO}_2, \text{V}^{+5}$ (d) $\text{Cu}_2\text{O}, \text{Cu}^{+2}$

72. For a reaction, $r = k(\text{CH}_3\text{COCH}_3)^{3/2}$ then unit of rate of reaction and rate constant respectively is

(a) $\text{mol L}^{-1} \text{s}^{-1}, \text{mol}^{-1/2} \text{L}^{1/2} \text{s}^{-1}$
 (b) $\text{mol}^{-1} \text{L}^{-1} \text{s}^{-1}, \text{mol}^{-1/2} \text{L}^{-1/2} \text{s}^{-1}$
 (c) $\text{mol L}^{-1} \text{s}^{-1}, \text{mol}^{+1/2} \text{L}^{1/2} \text{s}^{-1}$
 (d) $\text{mol L s}, \text{mol}^{+1/2} \text{L}^{1/2} \text{s}$

73. Which of the following is the correct statement for PH_3 ?

(a) It is less poisonous than NH_3 .
 (b) It is less basic than NH_3 .
 (c) Electronegativity of $\text{PH}_3 > \text{NH}_3$.
 (d) It does not show reducing properties.

74. If Si is doped with B,

(a) *n*-type semiconductor is formed
 (b) *p*-type semiconductor is formed
 (c) insulator is formed
 (d) polymer is formed.

75. Which has the highest pH?

(a) CH_3COOK (b) Na_2CO_3
 (c) NH_4Cl (d) NaNO_3

76. Living in the atmosphere of CO is dangerous, because it

(a) combines with O_2 present inside to form CO_2
 (b) reduces organic matter of tissues
 (c) combines with haemoglobin and makes it incapable to absorb oxygen
 (d) dries up the blood.

77. In a set of reactions, acetic acid yielded a product S.

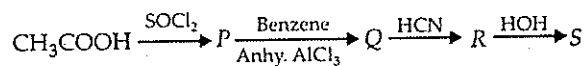

The structure of S would be

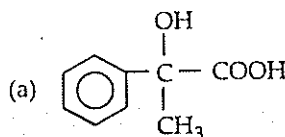

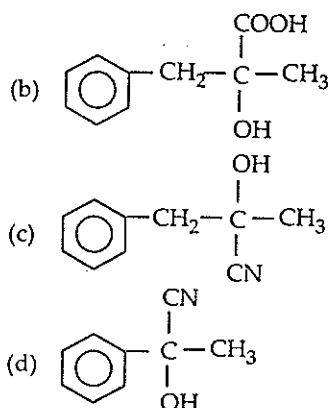

78. Which of the following is a chiral compound?
 (a) Hexane (b) *n*-Butane
 (c) Methane
 (d) 2,3,4-Trimethylhexane.
79. For $Zn^{2+} | Zn, E^\circ = -0.76 \text{ V}$ then EMF of the cell $Zn/Zn^{2+} (1M) | 2H^+ (1M) | H_2 (1 \text{ atm})$ will be
 (a) -0.76 V (b) 0.76 V
 (c) 0.38 V (d) -0.38 V
80. $\frac{K_p}{K_c}$ for following reaction will be
 $CO_{(g)} + \frac{1}{2} O_{2(g)} \rightarrow CO_{2(g)}$
 (a) RT (b) $\frac{1}{RT}$ (c) $\frac{1}{\sqrt{RT}}$ (d) $\frac{RT}{2}$
81. If $t_{1/2}$ vs $\frac{1}{a^2}$ is a straight line graph then determine the order of reaction.
 (a) Zero order (b) First order
 (c) Second order (d) Third order
82. CsCl has *bcc* arrangement. Its unit cell edge length is 400 pm. Its inter-ionic distance is
 (a) 400 pm (b) 800 pm
 (c) $\sqrt{3} \times 100 \text{ pm}$ (d) $\frac{\sqrt{3}}{2} \times 400 \text{ pm}$
83. A colloidal solution is kept in dark and is illuminated by a beam of light then brightness appears at the right angle of direction of light. This effect is called
 (a) Tyndall effect (b) Brownian effect
 (c) Hardy-Schulze effect
 (d) None of these
84. MnO_3 in an acidic medium dissociates into
 (a) MnO_2 and MnO_4^- (b) MnO and MnO_4^-
 (c) MnO_2 and MnO (d) MnO_2 and MnO_3
85. Magnetic moment of Cr^{2+} is nearest to
 (a) Fe^{2+} (b) Mn^{2+} (c) Co^{2+} (d) Ni^{2+}
86. Which of the following compounds are optically active?
- (1)
- (2)
- (3)
- (4)
- (a) 1 and 2 (b) 2 and 3
 (c) 3 and 4 (d) 1 and 4
87. Which will not form precipitation after addition of $(NH_4)_2CO_3$ in presence of NH_4Cl ?
 (a) Mg (b) Ba (c) Sn (d) Sr
88. Difference in atomic radius is maximum for
 (a) Rb-Cs (b) K-Rb
 (c) Na-K (d) Li-Na
89. The dipole moment is minimum in
 (a) NH_3 (b) NF_3 (c) SO_2 (d) BF_3
90. Number of isomers of C_5H_6
 (a) 2 (b) 3 (c) 4 (d) 5
91. At 60° and 1 atm, N_2O_4 is 50% dissociated into NO_2 then K_p is
 (a) 1.33 atm (b) 2 atm
 (c) 2.67 atm (d) 3 atm
92. pK_a increases in benzoic acid when substituent "x" is bonded at *para*-position, then "x" is
 (a) $-COOH$ (b) $-NO_2$
 (c) $-CN$ (d) $-OCH_3$
93. $S_2O_8^{2-}$ have
 (a) S-S bond (b) S-O bridge
 (c) O-O bridge
 (d) All S-O bond lengths are same.
94. N-N bond length is minimum in
 (a) N_2O (b) N_2O_3
 (c) N_2O_4 (d) N_2O_5
95. Which is correct example of condensation polymer?
 (a) Nylon, Buna-S (b) Teflon, Buna-N
 (c) Nylon 6,6, Dacron (d) Neoprene, Buna-S

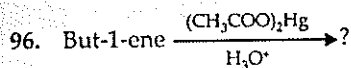

The product in the above reaction is

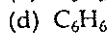
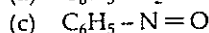
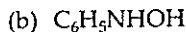
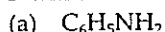
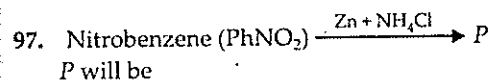
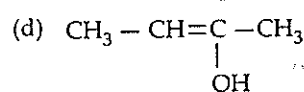
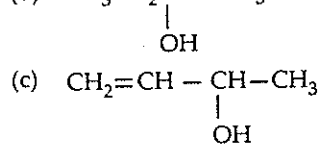
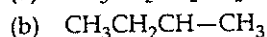
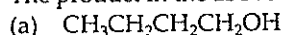

98. Which is correct order of solubility in water?

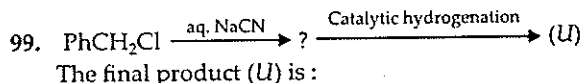
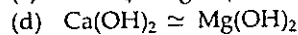
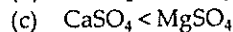
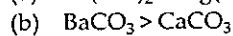
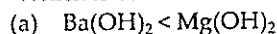

The final product (U) is:

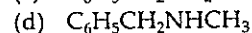
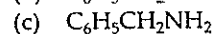
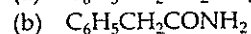
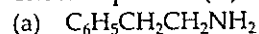

100. An aromatic compound $\text{C}_7\text{H}_6\text{Cl}_2$ (A), gives AgCl on boiling with alcoholic AgNO_2 solution and yields $\text{C}_7\text{H}_7\text{OCl}$ on treatment with sodium hydroxide. (A) on oxidation gives monochlorobenzoic acid. The compound (A) is:

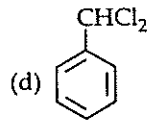
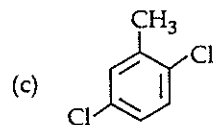
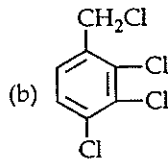
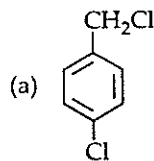

Directions : In the following questions (101-120), a statement of assertion (A) is followed by a statement of reason (R). Mark the correct choice as :

(a) If both assertion and reason are true and reason is the correct explanation of assertion

(b) If both assertion and reason are true but reason is not the correct explanation of assertion

(c) If assertion is true but reason is false

(d) If both assertion and reason are false.

101. Assertion : Rate of reaction doubles when concentration of reactant is doubled if it is a first order reaction.

Reason : Rate constant also doubles.

102. Assertion : Sodium acetate on Kolbe's electrolysis gives methane.

Reason : Methyl free radical is formed at cathode.

103. Assertion : H_3PO_2 has strong reducing property but H_3PO_4 does not.

Reason : P-OH bond present in H_3PO_4 .

104. Assertion : Diamond and graphite do not have the same crystal structure.

Reason : Diamond is crystalline while graphite is amorphous.

105. Assertion : Bohr model fails in case of multi-electron species.

Reason : It does not mention electron-electron interactions.

106. Assertion : 1, 2-dichloroethane is optically active.

Reason : Meso compound is optically active.

107. Assertion : ClF_3 has T-shape structure.

Reason : It has two lone pairs arranged at 180° angle.

108. Assertion : O_2 is paramagnetic.

Reason : It has one unpaired electron.

109. Assertion : Phenol is more reactive than benzene towards electrophilic substitution reaction.

Reason : In the case of phenol, the intermediate carbocation is more resonance stabilised.

110. Assertion : H_2Se is less acidic than H_2S .

Reason : S is less electronegative than Se.

111. Assertion : Fluorine is a stronger oxidizing agent than iodine.

Reason : Fluorine has greater electronegativity than iodine.

112. Assertion : Ce^{4+} is used as an oxidising agent in volumetric analysis.

Reason : Ce^{4+} has the tendency of attaining +3 oxidation state.

113. Assertion : The spectrum of He^+ is expected to be similar to that of hydrogen.

Reason : He^+ is also one electron system.

114. Assertion : Cl_2 gas bleaches the articles permanently.

Reason : Cl_2 is a strong reducing agent.

115. Assertion : $\text{La}(\text{OH})_3$ is more basic than $\text{Lu}(\text{OH})_3$.

Reason : Size of Lu^{3+} increases and shows more covalent character.

116. Assertion : F^- ion is a weak ligand and forms outer orbital complex.

Reason : F^- ion cannot force the electrons of d_z^2 and $d_x^2 - y^2$ orbitals of the inner shell to occupy d_{xy} , d_{yz} and d_{zx} orbitals of the same shell.

117. Assertion : $[\text{Fe}(\text{H}_2\text{O})_5\text{NO}]\text{SO}_4$ is paramagnetic.

Reason : The Fe in $[\text{Fe}(\text{H}_2\text{O})_5\text{NO}]\text{SO}_4$ has three unpaired electrons.

118. Assertion : The solubility of a gas in a liquid increases with increase of pressure.

Reason : The solubility of a gas in a liquid is directly proportional to the pressure of the gas.

119. Assertion : $\text{HC}\equiv\text{C}^-$ is more stable than $\text{H}_2\text{C}=\text{CH}^-$.

Reason : $\text{HC}\equiv\text{C}^-$ has more s-character than $\text{H}_2\text{C}=\text{CH}^-$.

120. Assertion : In a pressure cooker, the water is brought to boil. The cooker is then removed from the stove. Now on removing the lid of pressure cooker, the water starts boiling again.

Reason : The impurities in water bring down its boiling point.

BIOLOGY

121. Which of the following is correct regarding respiration in adult frog?

- In water- Skin, gills
- On land - Skin, buccal cavity
- In water- Skin, buccal cavity
- On land- Skin, lungs, gills.

122. Which of the following is correctly matched?

- Monstera*- Fibrous root
- Dahlia*- Fasciculated root
- Azadirachta* - Adventitious root
- Basil- Prop roots

123. The 'cells of Rauber' are

- secretory cells of endometrium in uterus
- inner cell mass of blastocoele
- outer cells of trophoblast in contact with uterine wall
- cells of trophoblast, in contact with inner cell mass of blastocyst.

124.

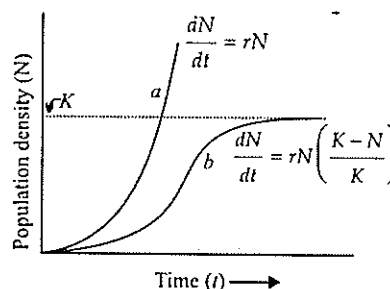

Which is correctly labelled with respect to the given diagram?

- B : Logistic curve
- C : Carrying capacity
- C : Exponential curve
- A : Carrying capacity

125. Deuteromycetes are known as fungi imperfecti because

- their zygote undergoes meroblastic and holoblastic cleavage
- only asexual stages are known
- they have aseptate mycelium
- they are autotrophic.

126. Abscisic acid is known as the stress hormone because it

- breaks seed dormancy
- induces flowering
- promotes leaf fall
- promotes closure of stomata.

127. Choose the correct statement.
- hPL plays a major role in parturition.
 - Foetus shows movements first time in the 7th month of pregnancy.
 - Signal for parturition comes from fully developed foetus and placenta.
 - Embryo's heart is formed by the 2nd month of pregnancy.
128. One of the world's most poisonous fish toxins is released by
- clown fish
 - sword fish
 - eel fish
 - puffer fish.
129. Na⁺/K⁺ pump is associated with
- passive transport
 - active transport
 - osmosis
 - imbibition.
130. Which one has the largest species variety in India?
- Wheat
 - Maize
 - Rice
 - Potato.
131. Photorespiration shows formation of
- sugar but not ATP
 - ATP but not sugar
 - both ATP and sugar
 - neither ATP nor sugar.
132. The microscope usually used for seeing living cells or tissues is
- compound microscope
 - electron microscope
 - phase contrast microscope
 - light microscope.
- 133.

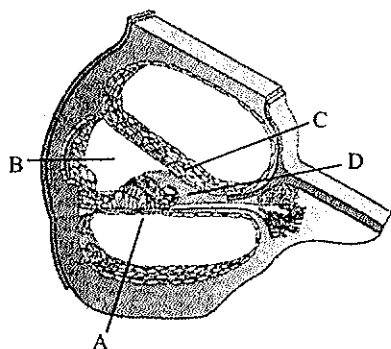



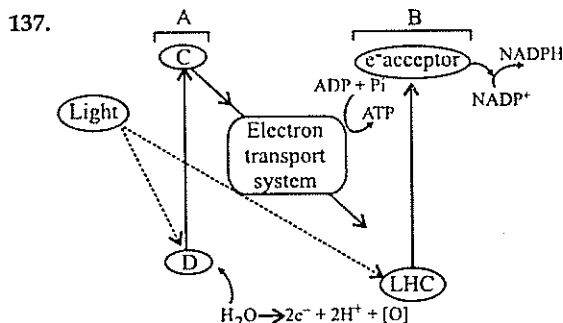

- Which of the following is correctly labelled?
- A : Reissner's membrane
 - B : Scala vestibuli
 - C : Basilar membrane
 - D : Tectorial membrane.

134. In aerobic respiration, total number of ATP molecules formed from 1 glucose molecule is
- 28
 - 32
 - 36
 - 30.
135. Which of the following cartoon characters does not share its name with that of a gene?
- Tintin
 - Popeye
 - Asterix
 - Obelix
136. Apiculture is associated with which of the following groups of plants?
- Grapes, maize, potato
 - Sugarcane, paddy, banana
 - Guava, sunflower, strawberry
 - Pineapple, sugarcane, strawberry.



Which of the following is correctly labelled for the given figure?

- A : PS II ; B : PS I ; C : e⁻ acceptor ; D : LHC
 - A : LHC ; B : e⁻ acceptor ; C : PS I ; D : PS II
 - A : PS I ; B : PS II ; C : e⁻ acceptor ; D : LHC
 - A : e⁻ acceptor ; B : LHC ; C : PS II ; D : PS I
138. During muscular contraction, which of the following events occur?
- H-zone disappears
 - A band widens
 - I band reduces in width
 - Width of A band is unaffected
 - M line and Z line come closer.
- (i), (iii), (iv) and (v)
 - (i), (ii) and (v)
 - (ii), (iv) and (v)
 - (i), (ii) and (iii).
139. The release of chemical messenger from synaptic vesicles is under the influence of these ion(s).
- Cl⁻
 - Fe⁺⁺ and S⁺⁺
 - Ca⁺⁺
 - Mg⁺⁺ and Sr⁺⁺

140. Cattle ranches are known to cause acute green house effect. This is due to
 (a) mechanized milking practices
 (b) methanogenic bacteria in rumen
 (c) decomposition of left over fodder
 (d) decomposition of organic remains in faeces.
141. Kranz anatomy is usually associated with
 (a) C_3 plants
 (b) C_4 plants
 (c) CAM plants
 (d) C_3 - C_4 intermediate plants.
142. Microtubule depolymerizing drug such as colchicine is expected to
 (a) inhibit spindle formation during mitosis
 (b) inhibit cytokinesis
 (c) allow mitosis beyond metaphase
 (d) induce formation of multiple contractile rings.
143. Catecholamine in a normal person induces
 (a) intense salivation
 (b) alertness
 (c) decrease in heart beat
 (d) excessive urination.
144. Select the option having all the correct characteristics.
- | Structure | Percentage | Function |
|---|------------|---------------------------------|
| (a)  | 0.3 – 0.5 | Phagocytic |
| (b)  | 0.5 – 1.0 | Secrete histamine and serotonin |
| (c)  | 30 – 40 | Defence against parasites |
| (d)  | 30 – 40 | Allergic reactions |
145. Plants with inferior ovary usually bear
 (a) pseudocarps (b) berries
 (c) aggregate fruits (d) seedless fruits.
146. Oxygen binding to haemoglobin in blood is
 (a) directly proportional to the concentration of CO_2 in the medium
 (b) inversely proportional to the concentration of CO_2 in the medium
 (c) directly proportional to the concentration of CO in the medium
 (d) independent of the concentration of CO in the medium.
147. Leghaemoglobin is produced in response to
 (a) respiration (b) photosynthesis
 (c) fatty acid synthesis (d) N_2 fixation.
148. The extinct human ancestor, who ate only fruits and hunted with stone weapons was
 (a) *Ramapithecus* (b) *Australopithecus*
 (c) *Dryopithecus* (d) *Homo erectus*.
149. What is common between earthworm and *Periplaneta*?
 (a) Both have red coloured blood
 (b) Both possess anal styles
 (c) Both have malpighian tubules
 (d) Both have segmented body.
150. In a normal adult, ascending order of concentration of following molecules is
 (a) $K > Na > Fe > Cu$ (b) $Na > K > Cu > Fe$
 (c) $Fe > Na > K > Cu$ (d) $Na > Fe > K > Cu$
151. Which of the following statements is incorrect about G_0 phase?
 (a) Mitosis occurs after G_0 phase.
 (b) Biocatalysts can be used to exit G_0 phase.
 (c) Cell volume keeps on increasing during this phase.
 (d) Cell metabolism occurs continuously in G_0 phase.
152. Beads on string like structures of A are seen in B, which further condense to form chromosomes in C stage of cell division.
- | A | B | C |
|----------------|------------|-----------|
| (a) Chromonema | Chromatin | Metaphase |
| (b) Chromatin | Chromatid | Metaphase |
| (c) Chromonema | Chromosome | Anaphase |
| (d) Chromonema | Chromatid | Anaphase. |
153. RNA interference is essential for the
 (a) cell proliferation (b) cell defence
 (c) cell differentiation (d) micropropagation.
154. Select the option having all correctly matched pairs.
- | | |
|----------------------|-----------------------------|
| A. Alkaloids | (i) Carotenoid; Anthocyanin |
| B. Pigments | (ii) Vinblastin; curcumin |
| C. Drugs | (iii) Morphine; Codeine |
| (a) A-i; B-ii; C-iii | (b) A-ii; B-iii; C-i |
| (c) A-iii; B-i; C-ii | (d) A-i; B-iii; C-ii. |

155. Dust, oolong and brick are varieties of
 (a) coffee (b) pepper
 (c) tea (d) lavang.
156. Ventricular diastole occurs due to a/an
 (a) organ system (b) cell organelle
 (c) tissue (d) organ.

157.

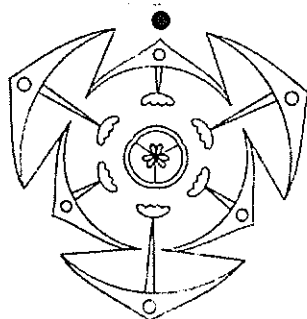

Plants having the above given floral diagram are

- (a) leguminous
 (b) dicots
 (c) medicinal and perennial
 (d) having pinnately compound leaves.
158. Select the correct statement.
 (a) Particulate matter of size 10 μm can create severe damage to the lungs.
 (b) Particulate matter of size greater than 2.5 μm can get trapped in lungs and cause problems.
 (c) Particulate matter of size less than 2.5 μm penetrate deep into lungs.
 (d) None of the above.
159. Pebrine in silkworms is caused by
 (a) *Dugesia* (b) *Monocystis*
 (c) *Nosema* (d) *Plasmodium*.
160. Which of the following is a homopolysaccharide?
 (a) Heparin (b) Inulin
 (c) Pectin (d) Hyaluronic acid.

Direction : In the following questions (161-180), a statement of assertion (A) is followed by a statement of reason (R). Mark the correct choice as :

- (a) If both assertion and reason are true and reason is the correct explanation of assertion
 (b) If both assertion and reason are true but reason is not the correct explanation of assertion
 (c) If assertion is true but reason is false
 (d) If both assertion and reason are false.

161. **Assertion :** There are 34 biodiversity hotspots in the world.

Reason : High level of species richness is a criteria for selection of a biodiversity hotspot.

162. **Assertion :** Inbreeding increases homozygosity, thus exposes harmful recessive genes, which are eliminated by selection.

Reason : Continued inbreeding reduces fertility and productivity.

163. **Assertion :** Some marine animals find it difficult to live in fresh water and *vice versa*.

Reason : Some animals can tolerate a narrow salinity range, while others can tolerate a wide salinity range.

164. **Assertion :** Myelin sheath insulates the nerve fibre and prevents its depolarisation.

Reason : Nerve impulses are conducted more rapidly in non - myelinated nerve fibres than in myelinated ones.

165. **Assertion :** Frog can change its colour, according to its surroundings.

Reason : It is a way of mimicry to capture preys.

166. **Assertion :** Less iodine intake causes goitre.

Reason : Less iodine in body decreases thyroxine secretion.

167. **Assertion :** $\text{Hb}^s \text{Hb}^s$ denotes the homozygous condition for sickle-cell anaemia.

Reason : It occurs due to substitution of glutamic acid by valine at the 6th position of β -chain of Hb.

168. **Assertion :** Excess Mn in soil, can adversely decrease Mg, Fe and Cu concentrations in the soil.

Reason : Mn increases rate of photosynthesis, thereby increasing absorption of Mg, Fe and Ca from soil.

169. **Assertion :** A middle aged woman is reported to have small breasts and undersized uterus.

Reason : Her genotypic analysis shows XO condition of allosomes.

170. Assertion : In proximal convoluted tubule glomerular filtrate becomes hypertonic to blood plasma.

Reason : HCO_3^- is absorbed only in the proximal convoluted tubule.

171. Assertion : Complexity of classification increases from kingdom to species.

Reason : Common characters increase from kingdom to species.

172. Assertion : In a terrestrial ecosystem, detritus food chain is the major conduit for energy flow.

Reason : Solar energy is the direct source for energy supply in a detritus food chain.

173. Assertion : Filarial worm is transmitted to humans by *Culex* mosquito.

Reason : *Culex* prefers to breed in fresh water.

174. Assertion : AIDS is caused by the HIV, a retrovirus.

Reason : Retroviruses have RNA genome.

175. Assertion : A male is found to be lacking facial hair and pubic hair.

Reason : It is a case of hyposecretion of testosterone from Leydig's cells of testes.

176. Assertion : Extra oxygen consumption in human body is known as oxygen debt.

Reason : The extra oxygen is required by the body to oxidise the accumulated lactic acid produced during strenuous exercise.

177. Assertion : Emulsification is necessary for the digestion of fats.

Reason : After fats are emulsified, the action of enzyme amylase gets significantly increased.

178. Assertion : In jaundice, the skin and mucous membranes assume a yellowish hue.

Reason : Yellow pigment bilirubin imparts pale yellow colour to blood plasma.

179. Assertion : No taste sensation is evoked when drop of distilled water is put on human tongue.

Reason : Man does not possess taste buds for tasting water.

180. Assertion : Oxytocin is also known as Anti-diuretic hormone (ADH).

Reason : Oxytocin can cause an increase in the renal reabsorption of water.

GENERAL KNOWLEDGE

181. The birth place of philosopher Ramanuja is the death place of which Prime Minister?

- (a) Indira Gandhi (b) Rajiv Gandhi
(c) Jawaharlal Nehru (d) Morarji Desai.

182. Which breed of dog does not bark?

- (a) Doberman (b) Basenji
(c) German Shepherd
(d) Dalmatian.

183. Which author of Indian origin was born in the Caribbean Nation of Trinidad and Tobago?

- (a) Salman Rushdie (b) V.S. Naipaul
(c) Shashi Tharoor (d) Nirad C. Chaudhuri.

184. Tezpur in north-east is famous for

- (a) hottest chilli in the world
(b) sweetest apple
(c) largest producer of gold
(d) largest producer of coal

185. Belt and Jacket, Catch-hold and loose styles are the basic types of which sport?

- (a) Boxing (b) Wrestling
(c) Kho-Kho (d) Kabaddi.

186. Kashmiri stag is also known as

- (a) Hangul (b) Nilgai
(c) Sambhar (d) Chital.

187. Who was the first Indian Prime Minister to lose an election?

- (a) Lal Bahadur Shastri
(b) V.P. Singh
(c) Morarji Desai (d) Indira Gandhi.

188. The city of Mysore has derived its name from the sanskrit word, for which of these?

- (a) Beautiful town (b) Buffalo town
(c) Great town (d) Golden town.

189. Which of the following persons founded Indian National Orchestra?

- (a) Zubin Mehta (b) Shankar Mahadevan
(c) A.R. Rehman (d) Ravi Shankar.
190. Which is the second highest civilian award in India?
(a) Bharat Ratna (b) Padma Vibhushan
(c) Padma Bhushan (d) Padma Shri.
191. Surface of which gemstone is called orient?
(a) Emerald (b) Emethyst
(c) Pearl (d) Diamond.
192. Which of the following states is the highest producer of soyabean in India?
(a) Uttar Pradesh (b) Andhra Pradesh
(c) Rajasthan (d) Madhya Pradesh.
193. Who captained India in woman cricket world cup 2000?
(a) Anju Jain (b) Neetu David
(c) Shantha Rangaswami
(d) Poornima Rao.
194. Which Union Territory has its name on the basis of a temple in the village Manimajra?
(a) Chandigarh (b) Lakshdweep
(c) Pondicherry (d) Daman and Diu.
195. In tricolour flag of India, saffron colour is a symbol of
(a) unity (b) sacrifice
(c) peace (d) prosperity.
196. Which of the following languages is not based on Devanagari script?
(a) Hindi (b) Sanskrit
(c) Nepali (d) Urdu.
197. Which one of the following is a military alliance?
(a) ASEAN (b) SAARC
(c) NATO (d) NAFTA.
198. 'Fanning and Dust', these terms are associated with
(a) tea (b) coffee
(c) soup (d) cold drink.
199. Which one of the following footballers is awarded Arjuna Award 2011?
(a) Sunil Chhetri (b) Baichung Bhutia
(c) Bruno Coutinho (d) I.M. Vijayan.
200. 'Cix's Bazar' is situated in
(a) Pakistan (b) Sri Lanka
(c) Bangladesh (d) Indonesia.